

# PANEL PC – NXP i.MX8M Mini Arm® Cortex®CPU

## 3HI30 Series

### FEATURES

- Scalable architectures with all NXP i.MX8M Mini
- SOM 3SM1008M, carrier 3PB1002
- Available with different display 7", 10.1", 15.6", 21.5" with CTP
- Customizable Panel PC
- Fanless system
- Boxed (CPT) and open frame version (RTP)
- Panel Mount and Standard Vesa mount
- Long longevity support
- HTML 5 supported

### APPLICATIONS

- Industrial Automation
- Industrial remote controls
- Construction machinery
- Smart Retail
- Intelligent Grid
- Warehouse Systems
- Vending machines
- Robot Industries

### CPU

- NXP i.MX8M Mini Dual/Quad up to 1,8GHz

### MEMORY

- Up to 4 GB DDR4 32bit

### STORAGE / BOOT

- Up to 64 GB eMMC
- µSD slot

### DISPLAY AND TOUCH

- Size available 7" - 10.1" - 15.6" - 21.5" IPS up to 1920x1080
- Capacitive touch screen (all size)
- Resistive touch screen (7" - 10.1")

### SYSTEM

- Single +12-24 VDC ±10% power supply



### PERIPHERALS<sup>1</sup>

- USB 2.0 Host
- USB 2.0 OTG
- Ethernet 1Gbps
- 1 x CAN BUS Interface with integrated Transceiver
- RS-232 (with hardware flow-control)
- RS-485 full duplex
- Expansion Connector
- BLE 5.0
- WiFi 2.4/5.0 GHz IEEE 802.11 b/g/n
- Buzzer
- Temperature sensor
- RTC
- microSD slot

### TEMPERATURE<sup>2</sup>

- 0° to 60°C
- -20°C to +70°C

### OPERATING SYSTEMS

- Linux Embedded

### HMI DEVELOP SDK<sup>3</sup>

- HTML5 supported
- QT

<sup>1</sup> Please note that not all the functions may be available simultaneously, due to pin mux limitation of CPU case. We can check if our SoM is compatible with your application, contact us for more information

<sup>2</sup> These temperatures are the ambient operating temperature ranges for the components used into SoM, with exception of i.MX8M series which is specified on junction operating temperature range. Panel PC ambient operating temperature depends on the application and on the cooling measures applied

<sup>3</sup> QT support is only under requests from Customer, all responsibility and license costs are in charge on customer



Standard Panel PC ordering code

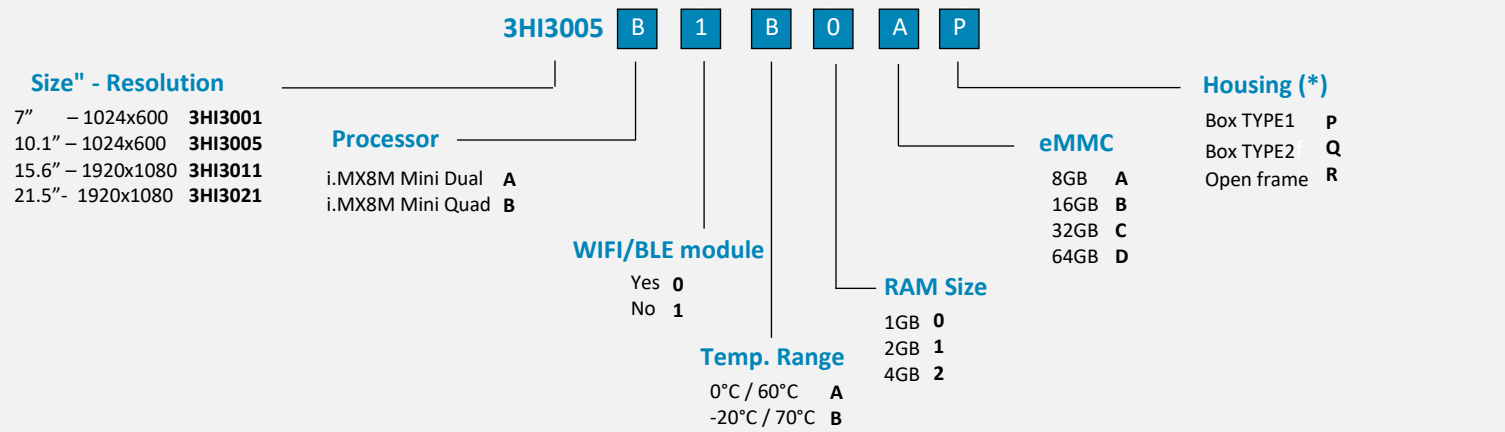

No all code combinations are allowed, for more information on ordering codes please contact Elettronica GF sales department

(\*) BOX Type 1: all Display Size only CTP

(\*) BOX Type 2: only 7" – 10,1" CTP

(\*) Open Frame: only 7" – 10,1" RTP

